

Product Summary

- $V_{DS} = 20V, I_D = 6A$
- $R_{DS(on)} < 25m\Omega @ V_{GS} = 4.5V$
- $R_{DS(on)} < 35m\Omega @ V_{GS} = 2.5V$

Features

- Advanced Trench Technology
- RoHS and Reach Compliant
- Halogen and Antimony Free
- Moisture Sensitivity Level 3

Application

- Load Switch
- PWM Application
- Power Management

Marking Code

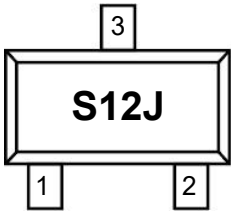

SOT-23

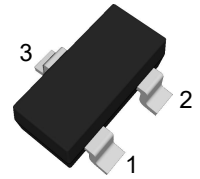

(Top View)

Pin	Description
1	Gate
2	Source
3	Drain

Schematic Diagram

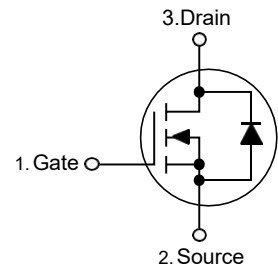

Absolute Maximum Ratings

($T_a = 25^\circ C$ unless otherwise specified)

Parameter	Symbol	Value	Unit
Drain-Source Voltage	V_{DS}	20	V
Gate-Source Voltage	V_{GS}	± 12	V
Drain Current-Continuous	I_D	6	A
Drain Current-Pulsed ^{Note1}	I_{DM}	20	A
Maximum Power Dissipation	P_D	1	W
Junction Temperature	T_J	150	$^\circ C$
Storage Temperature Range	T_{STG}	-55 to +150	$^\circ C$

Thermal Characteristics

Thermal Resistance, Junction-to-Ambient ^{Note2}	$R_{\theta JA}$	125	$^\circ C/W$
--	-----------------	-----	--------------

Electrical Characteristics

(Ta=25°C unless otherwise specified)

Parameter	Symbol	Test Condition	Min.	Typ.	Max.	Unit
Static Characteristics						
Drain-Source Breakdown Voltage	$V_{(BR)DSS}$	$V_{GS}=0V, I_D=250\mu A$	20	--	--	V
Zero Gate Voltage Drain Current	I_{DSS}	$V_{DS}=20V, V_{GS}=0V$	--	--	1	μA
Gate-Body Leakage Current	I_{GSS}	$V_{GS}=\pm 12V, V_{DS}=0V$	--	--	± 100	nA
Gate Threshold Voltage ^{Note3}	$V_{GS(th)}$	$V_{DS}=V_{GS}, I_D=250\mu A$	0.45	0.7	1	V
Drain-Source On-Resistance ^{Note3}	$R_{DS(on)}$	$V_{GS}=4.5V, I_D=4.5A$	--	18	25	m Ω
		$V_{GS}=2.5V, I_D=4A$	--	21	35	m Ω
Forward Transconductance ^{Note3}	g_{FS}	$V_{DS}=5V, I_D=1A$	--	5	--	S
Dynamic Characteristics						
Input Capacitance	C_{iss}	$V_{DS}=8V, V_{GS}=0V, f=1MHz$	--	688	--	pF
Output Capacitance	C_{oss}		--	102	--	pF
Reverse Transfer Capacitance	C_{rss}		--	90	--	pF
Gate Resitance	R_g	$V_{DS}=0V, V_{GS}=0V, f=1MHz$	--	32	--	Ω
Total Gate Charge	Q_g	$V_{DS}=10V, I_D=3A,$ $V_{GS}=0V\sim 4.5V$	--	9.3	--	nC
Gate-Source Charge	Q_{gs}		--	1.5	--	nC
Gate-Drain Charge	Q_{gd}		--	2	--	nC
Switching Characteristics						
Turn-on Delay Time	$t_{d(on)}$	$V_{DD}=10V, I_D=3A,$ $V_{GS}=4.5V, R_{GEN}=3\Omega$	--	4	--	nS
Turn-on Rise Time	t_r		--	18	--	nS
Turn-off Delay Time	$t_{d(off)}$		--	106	--	nS
Turn-off Fall Time	t_f		--	64	--	nS
Source-Drain Diode Characteristics						
Diode Forward Voltage ^{Note3}	V_{SD}	$V_{GS}=0V, I_S=6A$	--	--	1.2	V
Diode Forward Current ^{Note2}	I_S		--	--	6	A

Note: 1. Repetitive Rating: Pulse width limited by maximum junction temperature.

 2. Surface Mounted on FR4 Board, $t \leq 10$ sec.

 3. Pulse Test: Pulse width $\leq 300\mu s$, duty cycle $\leq 2\%$.

Typical Characteristic Curves

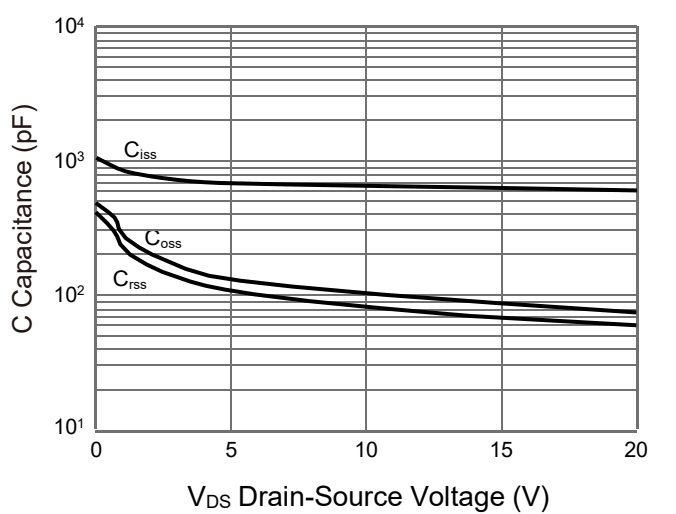
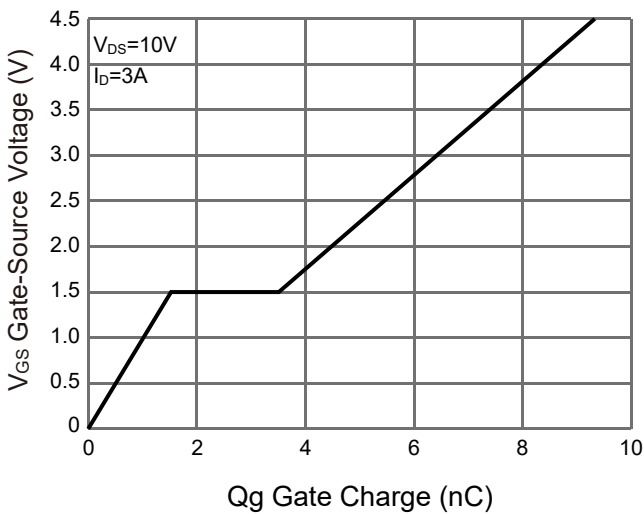
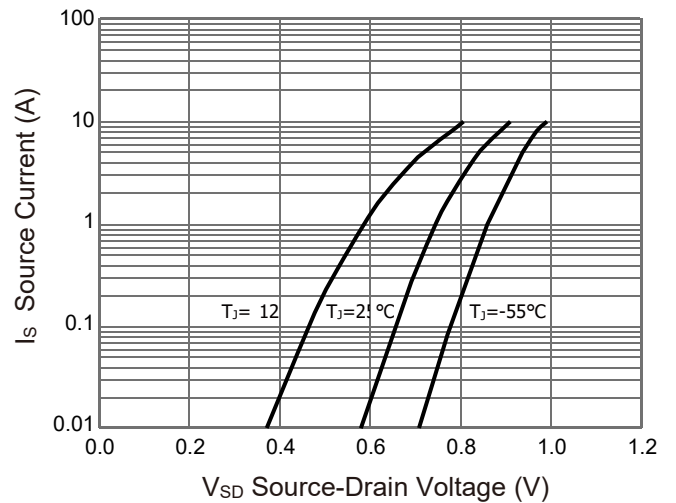
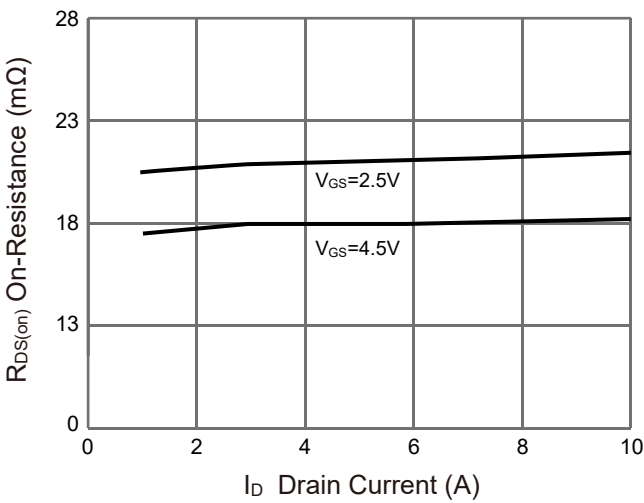
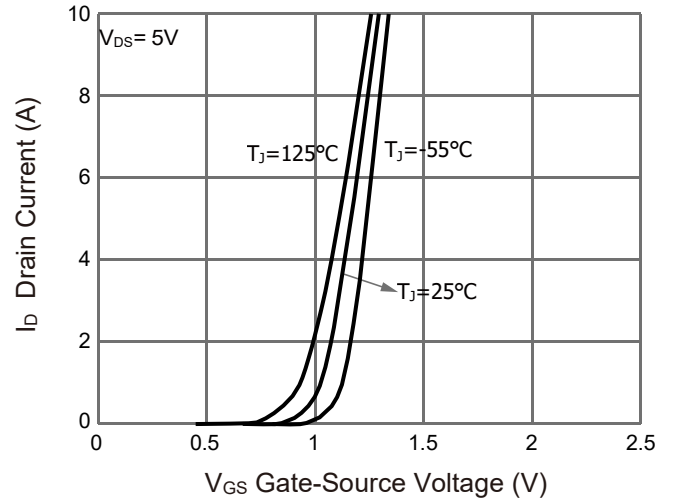
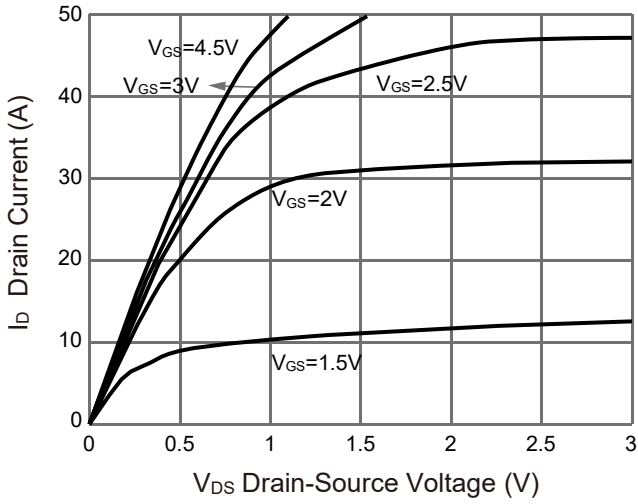

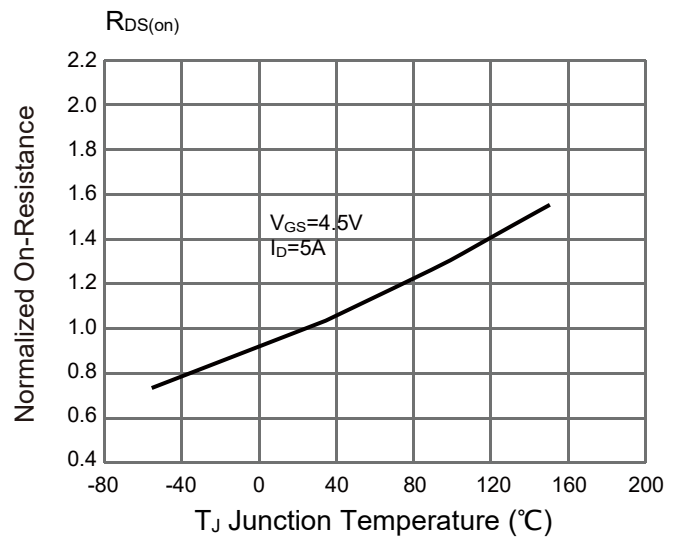
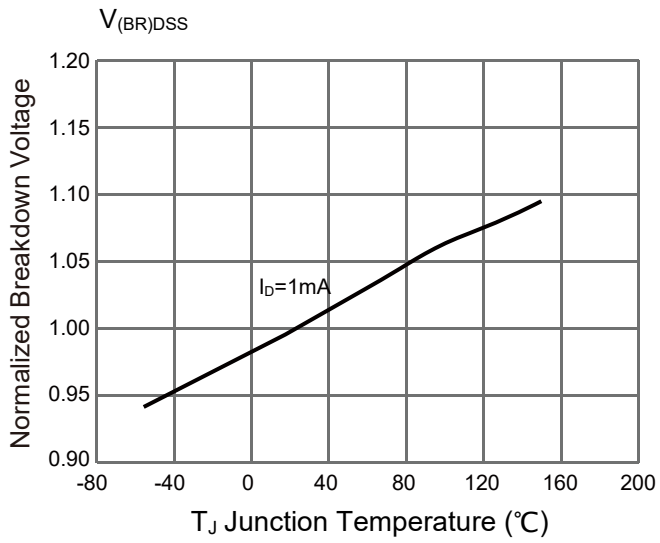

Package Outline

SOT-23

Dimensions in mm

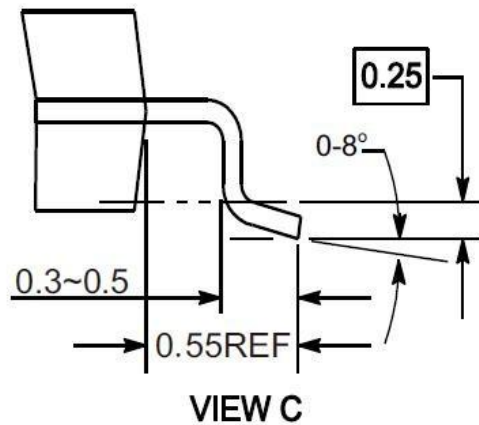
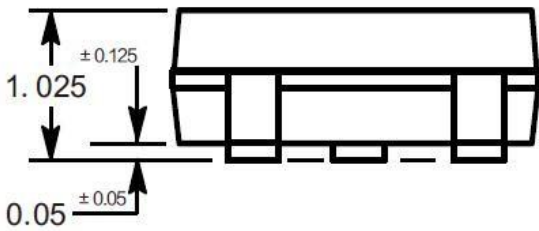
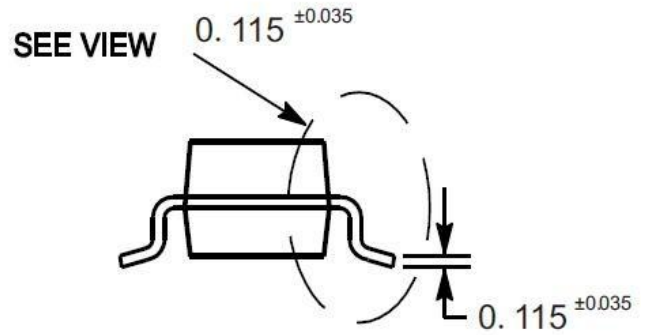
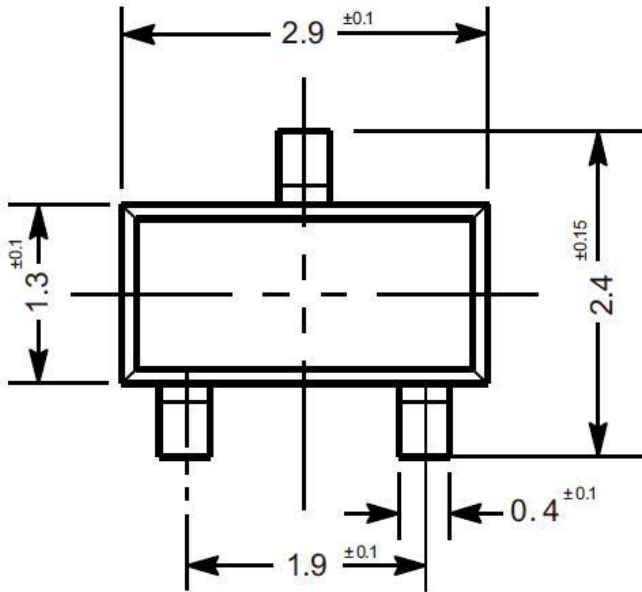
Ordering Information

Device	Package	Shipping
TN2312JNSA	SOT-23	3,000PCS/Reel&7inches

Conditions of Soldering and Storage

◆ Recommended condition of reflow soldering

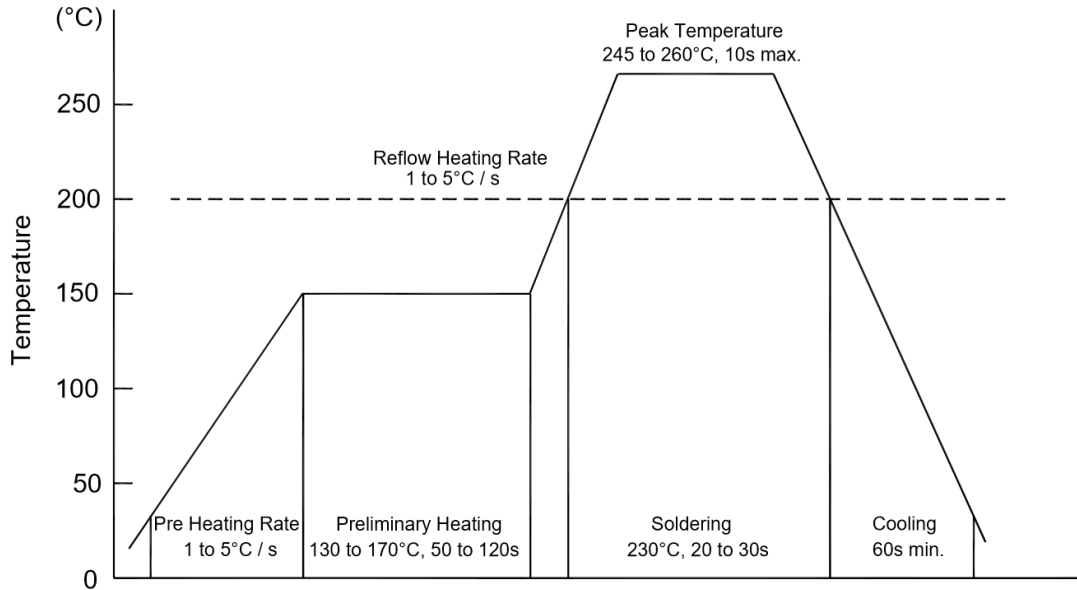

Recommended peak temperature is over 245°C. If peak temperature is below 245°C, you may adjust the following parameters:

- Time length of peak temperature (longer)
- Time length of soldering (longer)
- Thickness of solder paste (thicker)

◆ Conditions of hand soldering

- Temperature: 300°C
- Time: 3s max.
- Times: one time

◆ Storage conditions

● Temperature

5 to 40°C

● Humidity

30 to 80% RH

● Recommended period

One year after manufacturing

Package Specifications

- The method of packaging

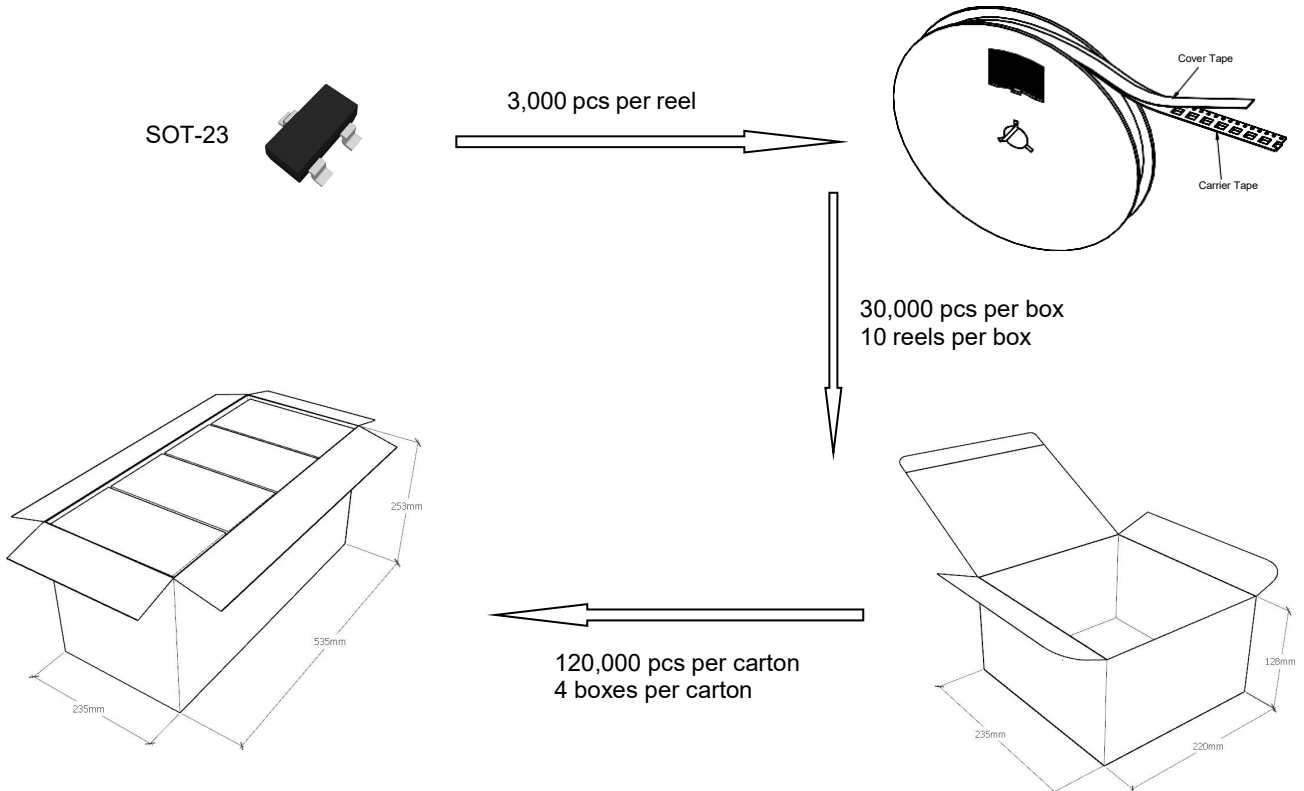

◆ Embossed tape and reel data

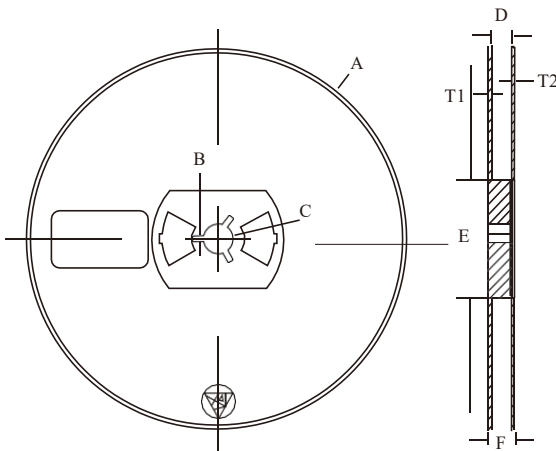

Symbol	Value (unit: mm)
A	Ø 177.8±1
B	2.7±0.2
C	Ø 13.5±0.2
E	Ø 54.5±0.2
F	12.3±0.3
D	9.6+2/-0.3
T1	1.0±0.2
T2	1.2±0.2

Reel (7")

