

## P-Channel Enhancement Mode Power MOSFET SOT-23

### Product Summary

- $V_{DS} = -30V, I_D = -4.2A$
- $R_{DS(on)} < 60m\Omega @ V_{GS} = -10V$
- $R_{DS(on)} < 85m\Omega @ V_{GS} = -4.5V$

### Features

- Advanced Trench Technology
- RoHS and Reach Compliant
- Halogen and Antimony Free
- Moisture Sensitivity Level 3

### Application

- Load Switch
- PWM Application

### Marking Code

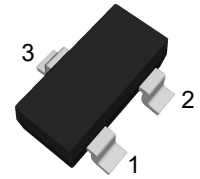
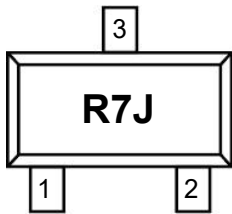

(Top View)

Pin	Description
1	Gate
2	Source
3	Drain

### Schematic Diagram

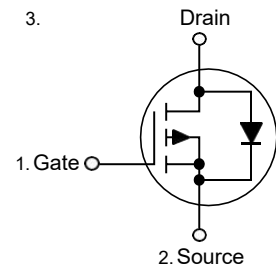

### Absolute Maximum Ratings

( $T_a = 25^\circ C$  unless otherwise specified)

Parameter	Symbol	Value	Unit
Drain-Source Voltage	$-V_{DS}$	30	V
Gate-Source Voltage	$V_{GS}$	$\pm 20$	V
Drain Current-Continuous	$-I_D$	4.2	A
Drain Current-Pulsed <sup>Note1</sup>	$-I_{DM}$	16	A
Maximum Power Dissipation	$P_D$	1	W
Junction Temperature	$T_J$	150	$^\circ C$
Storage Temperature Range	$T_{STG}$	-55 to +150	$^\circ C$

### Thermal Characteristics

Thermal Resistance, Junction-to-Ambient <sup>Note2</sup>	$R_{\theta JA}$	125	$^\circ C/W$
--	-----------------	-----	--------------

**Electrical Characteristics**

(Ta=25°C unless otherwise specified)

Parameter	Symbol	Test Condition	Min.	Typ.	Max.	Unit
<b>Static Characteristics</b>						
Drain-Source Breakdown Voltage	$-V_{(BR)DSS}$	$V_{GS}=0V, I_D=-250\mu A$	30	--	--	V
Zero Gate Voltage Drain Current	$-I_{DSS}$	$V_{DS}=-30V, V_{GS}=0V$	--	--	1	$\mu A$
Gate-Body Leakage Current	$I_{GSS}$	$V_{GS}=\pm 20V, V_{DS}=0V$	--	--	$\pm 100$	nA
Gate Threshold Voltage <sup>Note3</sup>	$-V_{GS(th)}$	$V_{DS}=V_{GS}, I_D=-250\mu A$	1	1.5	3	V
Drain-Source On-Resistance <sup>Note3</sup>	$R_{DS(on)}$	$V_{GS}=-10V, I_D=-4.1A$	--	43	60	m $\Omega$
		$V_{GS}=-4.5V, I_D=-3A$	--	56	85	m $\Omega$
Forward Transconductance <sup>Note3</sup>	$g_{FS}$	$V_{DS}=-5V, I_D=-1A$	--	5	--	S
<b>Dynamic Characteristics</b>						
Input Capacitance	$C_{iss}$	$V_{DS}=-15V, V_{GS}=0V, f=1MHz$	--	380	--	pF
Output Capacitance	$C_{oss}$		--	57	--	pF
Reverse Transfer Capacitance	$C_{rss}$		--	33	--	pF
Gate Resistance	$R_G$	$V_{DS}=0V, V_{GS}=0V, f=1MHz$	--	140	--	$\Omega$
Total Gate Charge	$Q_g$	$V_{DD}=-15V, I_D=-4.1A,$ $V_{GS}=-10V$	--	6.8	--	nC
Gate-Source Charge	$Q_{gs}$		--	1	--	nC
Gate-Drain Charge	$Q_{gd}$		--	1.4	--	nC
<b>Switching Characteristics</b>						
Turn-on Delay Time	$t_{d(on)}$	$V_{DD}=-15V, I_D=-1A$ $V_{GS}=-10V, R_{GEN}=2.5\Omega$	--	14	--	nS
Turn-on Rise Time	$t_r$		--	61	--	nS
Turn-off Delay Time	$t_{d(off)}$		--	19	--	nS
Turn-off Fall Time	$t_f$		--	10	--	nS
<b>Source-Drain Diode Characteristics</b>						
Diode Forward Voltage <sup>Note3</sup>	$-V_{SD}$	$V_{GS}=0V, I_S=-4.2A$	--	--	1.2	V
Diode Forward Current <sup>Note2</sup>	$-I_S$		--	--	4.2	A

Note: 1. Repetitive Rating: Pulse width limited by maximum junction temperature.

 2. Surface Mounted on FR4 Board,  $t \leq 10$  sec.

 3. Pulse Test: Pulse width  $\leq 300\mu s$ , duty cycle  $\leq 2\%$ .

## Typical Characteristic Curves

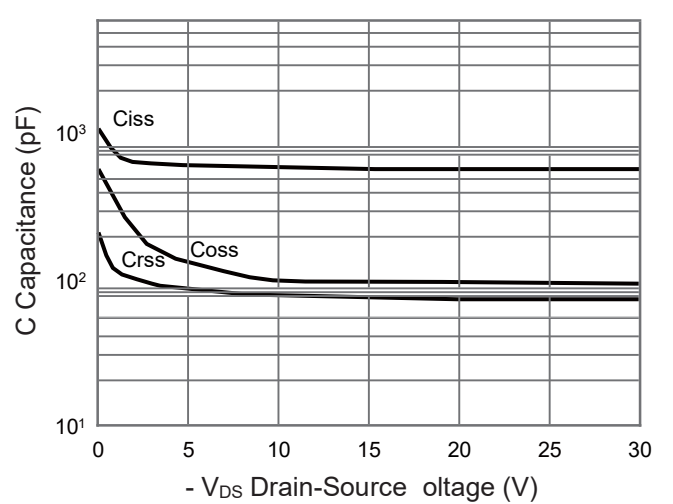
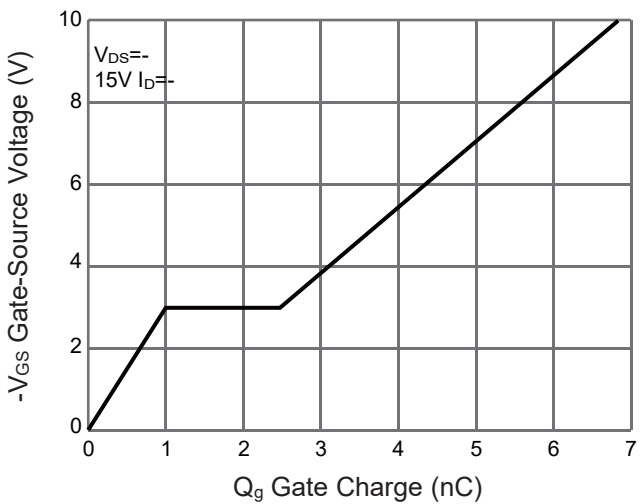
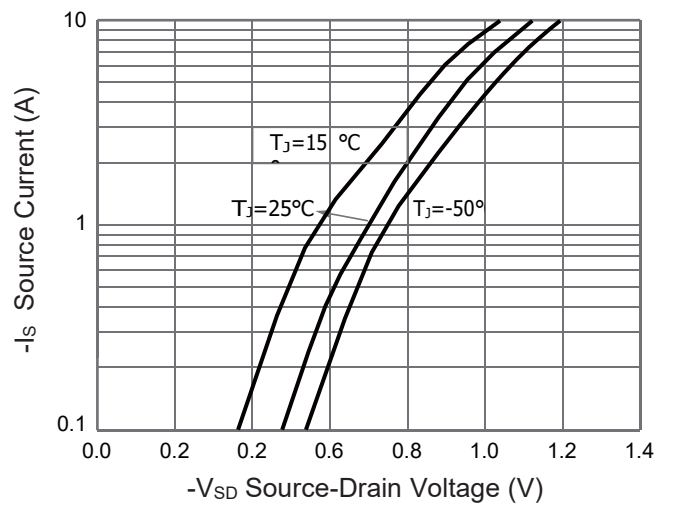
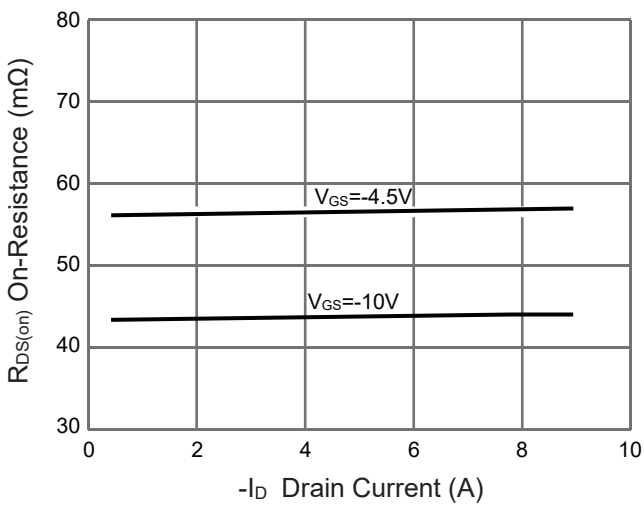
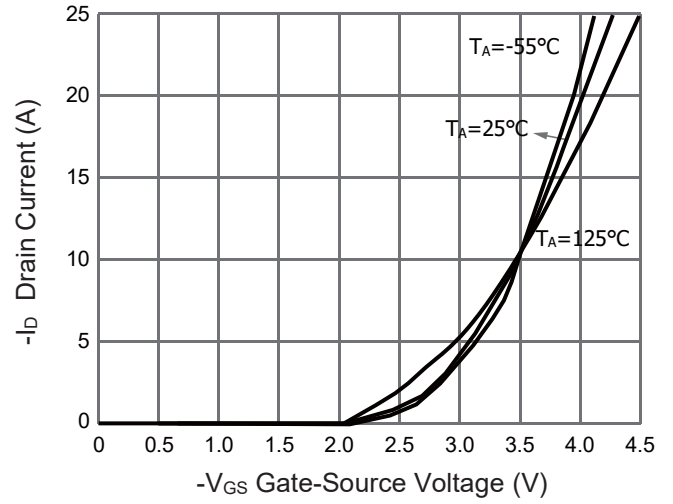
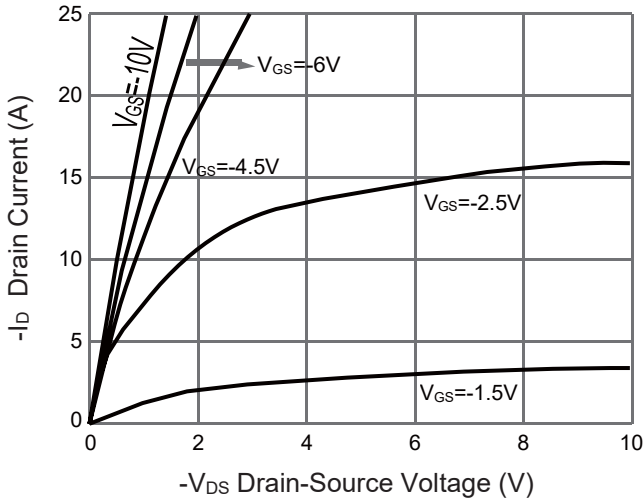

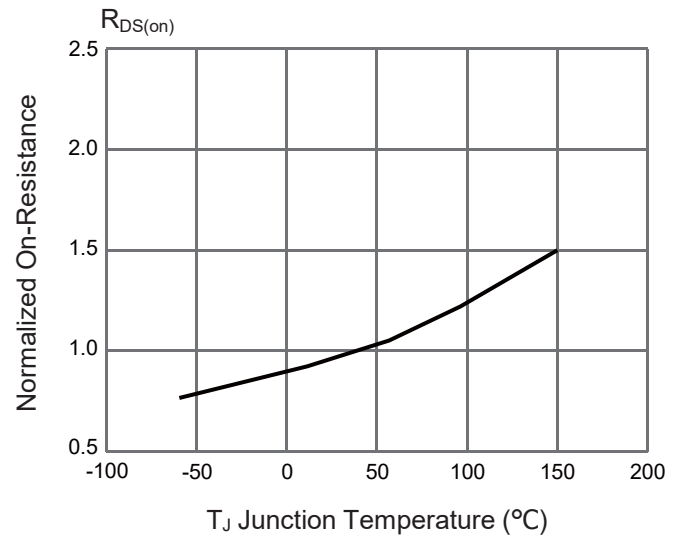
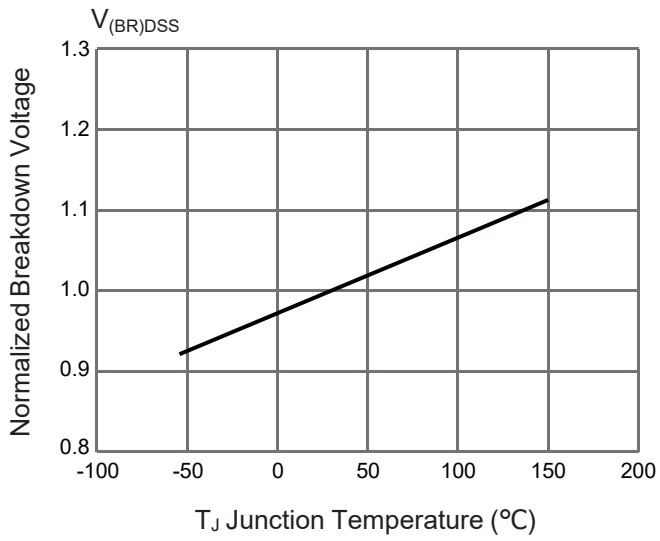

## Package Outline

SOT-23

Dimensions in mm

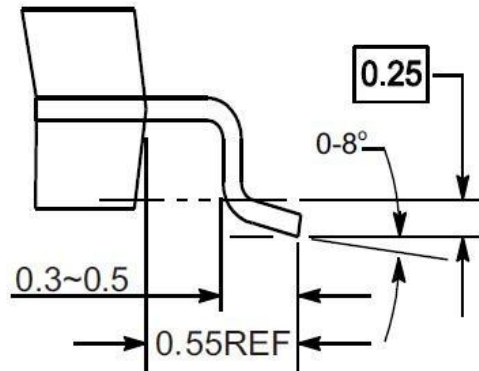
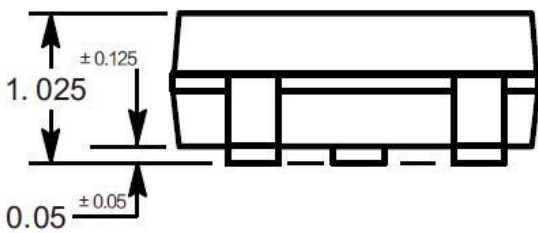
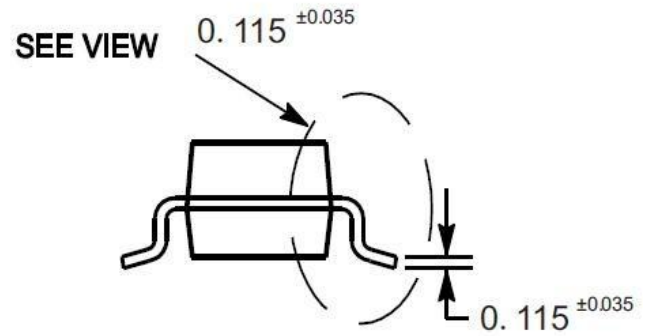
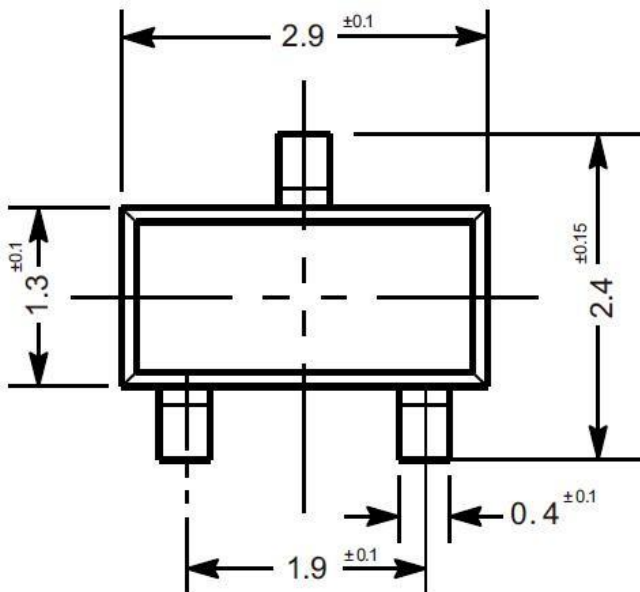

VIEW C

## Ordering Information

Device	Package	Shipping
TN3407JPSA	SOT-23	3,000PCS/Reel&7inches

## Conditions of Soldering and Storage

### ◆ Recommended condition of reflow soldering

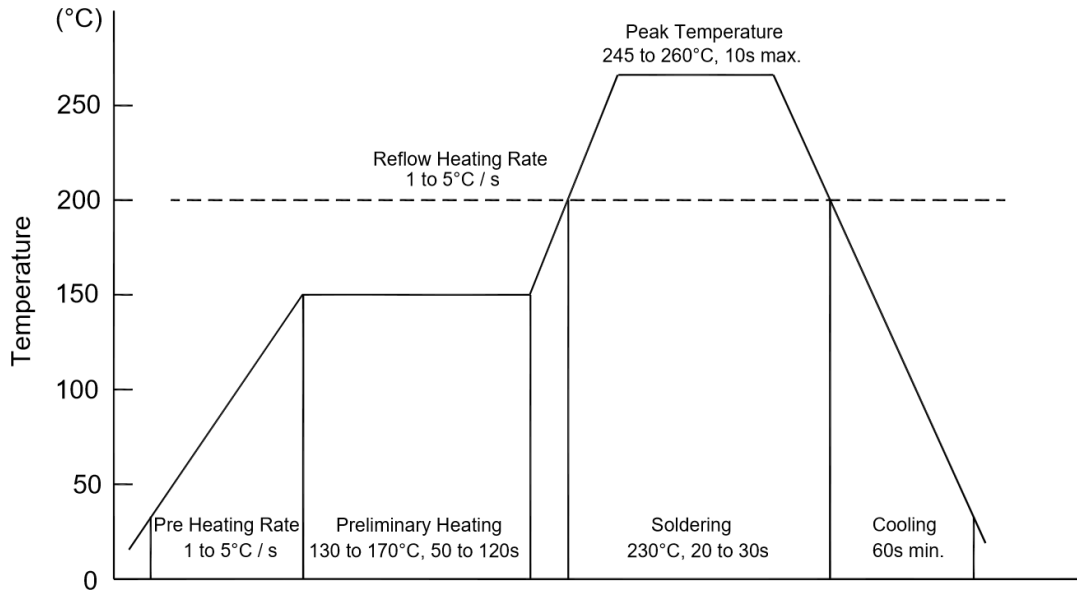

Recommended peak temperature is over 245°C. If peak temperature is below 245°C, you may adjust the following parameters:

- Time length of peak temperature (longer)
- Time length of soldering (longer)
- Thickness of solder paste (thicker)

### ◆ Conditions of hand soldering

- Temperature: 300°C
- Time: 3s max.
- Times: one time

### ◆ Storage conditions

#### ● Temperature

5 to 40°C

#### ● Humidity

30 to 80% RH

#### ● Recommended period

One year after manufacturing

## Package Specifications

- The method of packaging

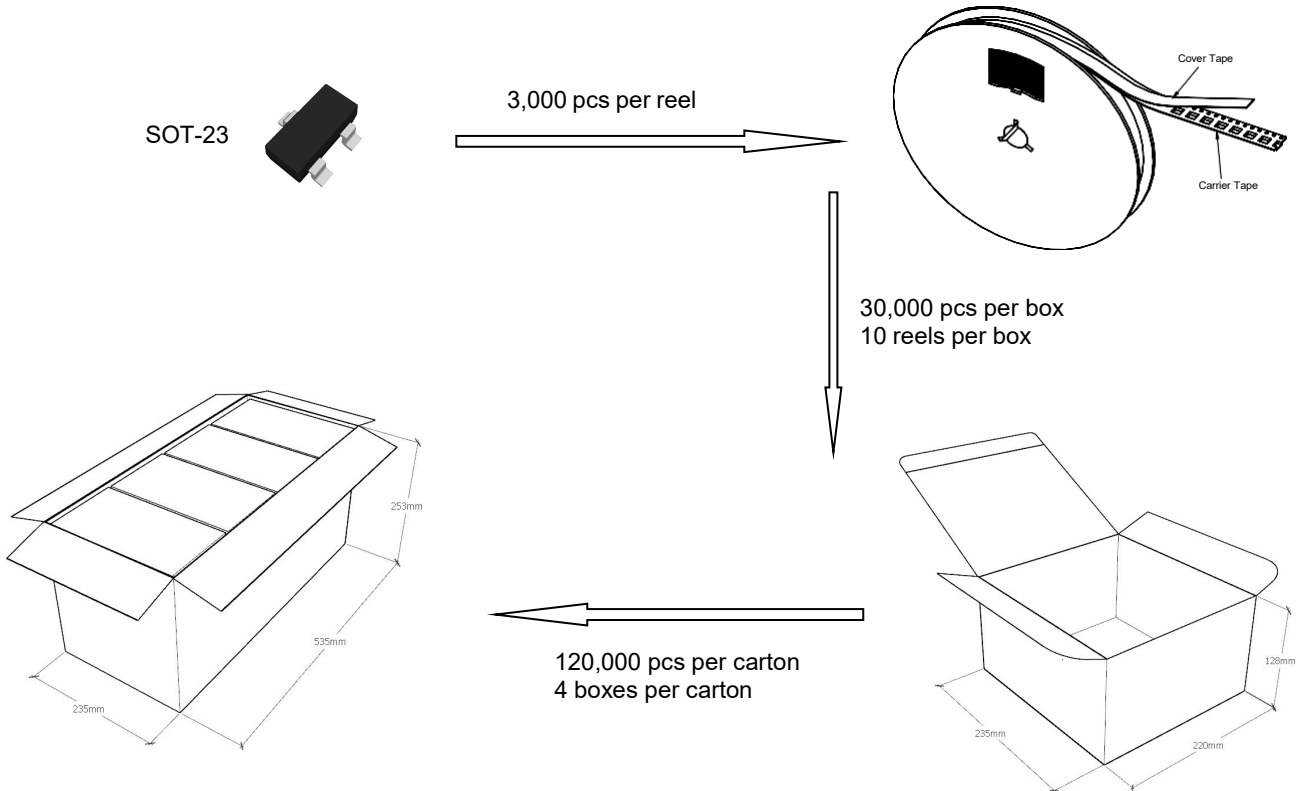

## ◆ Embossed tape and reel data

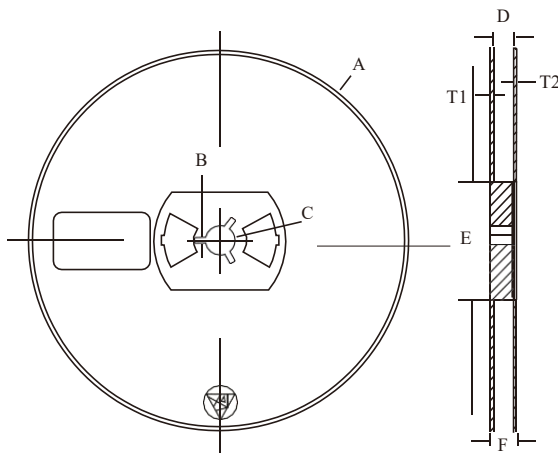

Symbol	Value (unit: mm)
A	Ø 177.8±1
B	2.7±0.2
C	Ø 13.5±0.2
E	Ø 54.5±0.2
F	12.3±0.3
D	9.6+2/-0.3
T1	1.0±0.2
T2	1.2±0.2

